

TRULINE[®]

The Innovative Hybrid Sheet Piling System

Drawing 115

temporary flood diversion wall concept

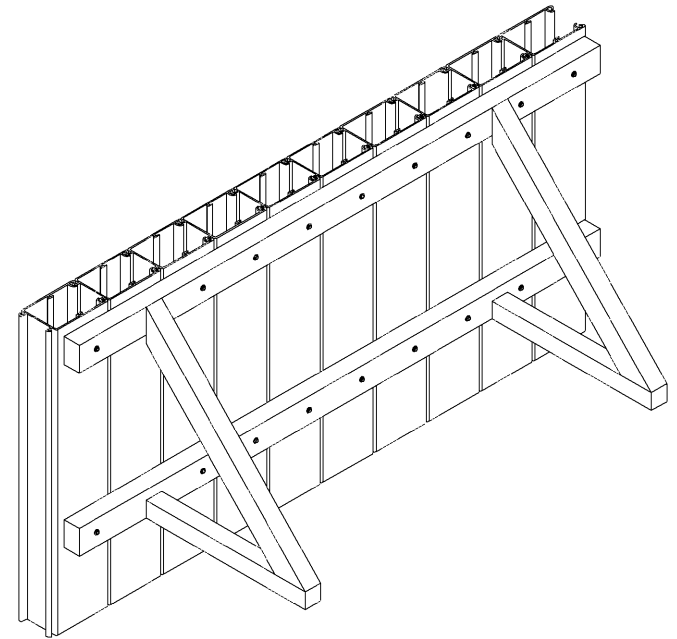
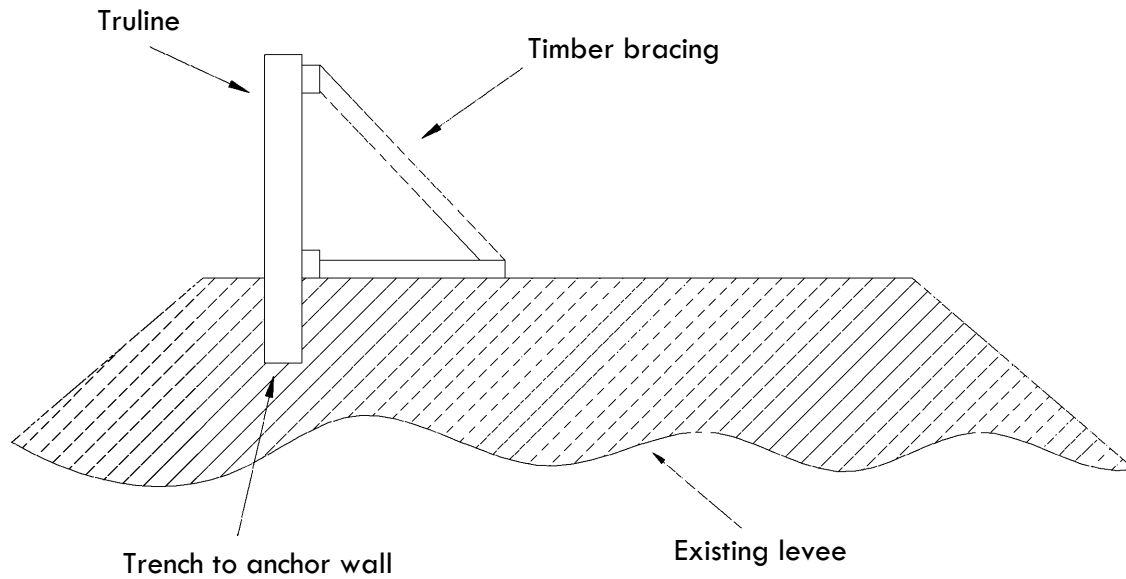

This drawing is provided to show a typical concept for constructing a wall of this style. It is not intended to be used as a final design for any specific project. There are many geotechnical and structural properties that have to be considered in the design of a project. These factors vary depending on conditions that are potentially unique to each jobsite. As such, project specific designs must be performed by a qualified engineer familiar with the conditions on the actual site.

www.truline.us

©2008-17 Truline LLC. Truline is a registered trademark of Truline LLC. US Patent No. 7628370, 8033759. Other patents pending. All rights reserved.